

3D Vision & AI for Robots and More

Mech-Mind Robotics Product Catalog

We Help Integrators WIN
with best-in-class AI + 3D vision tools and services.

Advanced Techs | Proven | Versatile | Fast and Easy | No Black-Box | Industry-Ready | Open | Best Services

Empower System Integrators with Advanced AI + 3D Vision Tools

Mech-Mind is an industry-leading provider of industrial 3D cameras and AI software suites for robotic applications. With the comprehensive product portfolio, Mech-Mind empowers partners and system integrators to manage the most demanding robotic applications and brings automation to the next level.

Mech-Eye Industrial 3D Cameras



- High accuracy
- Fast scanning
- Resistance to ambient light
- IP65/IP67 protection and CE, FCC, VCCI, KC, ISED, NRTL, and RoHS certified
- Multiple model options



High-quality 3D data

Mech-Vision Machine Vision Software



- Code-free graphical user interface
- Extensive solution library
- Easy integration
- Various vision tools integrated
- Integrates 1,000+ robot models

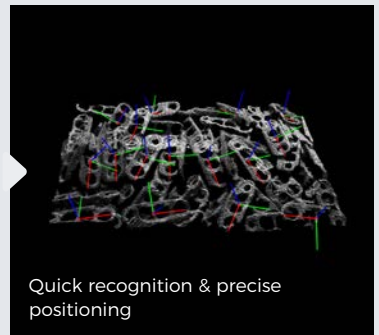

Quick recognition & precise positioning

Mech-DLK Deep Learning Software



- Intuitive graphical user interface
- Visualized model validation
- Simple labeling and fast training
- Easy integration using multi-language SDKs, including C, C++, C#, and Python
- Standalone AI software for quality control



Intuitive & efficient model training

Mech-Viz Robot Programming Software



- Task-oriented graphical programming interface
- One-click simulation
- Powerful algorithms
- Support for almost all major-brand robots



Robot accomplishes complex tasks

Mech-Eye Industrial 3D Cameras

Scan the QR code to access datasheets



- Detailed and accurate 3D point clouds
- Ambient light resistance
- Short capture time
- IP65 water and dust resistance
- Rugged aluminum alloy housing
- MTBF (Mean Time Between Failures): $\geq 100,000$ hours

Specification	LSR XL-GL	LSR L-GL	LSR S-GL	PRO M-GL	PRO S-GL
Working distance ^[1]	1600-3500 mm	1200-3000 mm	500-1500 mm	1000-2000 mm	500-1000 mm
Near FOV	1280 x 1280 mm @ 1.6 m	1200 x 1000 mm @ 1.2 m	480 x 360 mm @ 0.5 m	800 x 450 mm @ 1.0 m	370 x 240 mm @ 0.5 m
Far FOV	3000 x 2800 mm @ 3.5 m	3000 x 2400 mm @ 3.0 m	1500 x 1200 mm @ 1.5 m	1500 x 890 mm @ 2.0 m	800 x 450 mm @ 1.0 m
Resolution	Depth map: 2448 x 2040	Depth map: 2048 x 1536	Depth map: 2048 x 1536	1920 x 1200	1920 x 1200
	RGB: 4000 x 3000/ 2000 x 1500	RGB: 4000 x 3000/ 2000 x 1500	RGB: 4000 x 3000/ 2000 x 1500		
Megapixels	/	/	/	2.3 MP	2.3 MP
Point repeatability Z (σ) ^[2]	0.2 mm @ 3.0 m	0.5 mm @ 3.0 m	0.2 mm @ 1.5 m	0.2 mm @ 2.0 m	0.05 mm @ 1.0 m
VDI/VDE accuracy ^[3]	1.0 mm @ 3.0 m	1.0 mm @ 3.0 m	1.0 mm @ 1.5 m	0.2 mm @ 2.0 m	0.1 mm @ 1.0 m
Typical capture time	0.6-1.1 s	0.5-0.9 s	0.5-0.9 s	0.3-0.6 s	0.3-0.6 s
Baseline	800 mm	380 mm	140 mm	270 mm	180 mm
Dimensions	942 x 88 x 116 mm	459 x 77 x 86 mm	228 x 77 x 126 mm	353 x 57 x 100 mm	265 x 57 x 100 mm
Weight	4.5 kg	2.9 kg	1.9 kg	1.9 kg	1.6 kg
Light source	Red laser (638 nm, Class 2)			Blue LED (459 nm, RG2)/White LED(RG2)	
Image sensor	Sony CMOS for high-end machine vision				
Operating temperature	-10-45°C			0-45°C	
Communication interface	Gigabit Ethernet				
Input	24V DC, 3.75 A				
Safety and EMC	CE/FCC/VCCI/KC/ISED/NRTL				
IP rating	IP65		IP67	IP65	
Cooling	Passive				

**Mech-Eye
LSR XL-GL**

**Mech-Eye
LSR L-GL**

**Mech-Eye
LSR S-GL**

**Mech-Eye
PRO M-GL**

**Mech-Eye
PRO S-GL**

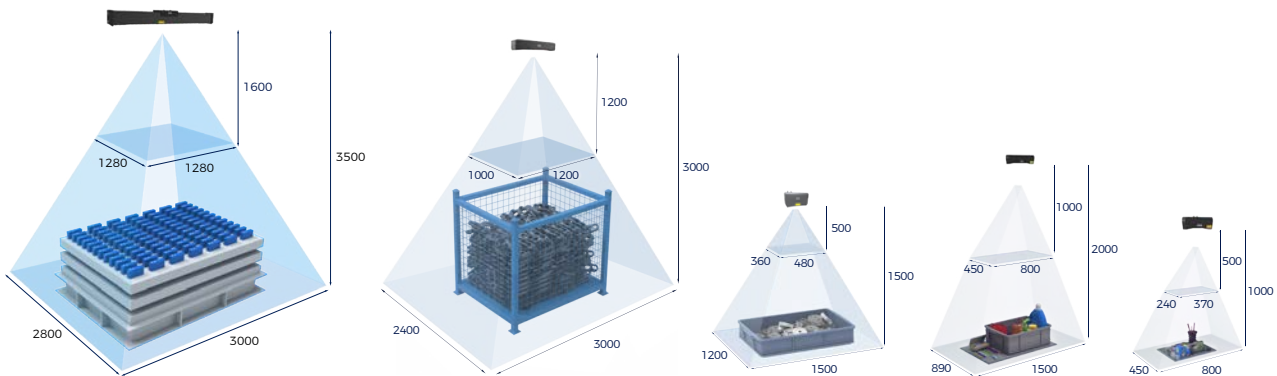

Field of view (mm)

[1] Multiple focal distances are available in a camera model. For further details, please scan the QR code to access camera datasheets.

[2] One standard deviation of 100 Z-value measurements of the same point. The measurement target was a ceramic plate.

[3] According to VDI/VDE 2634 Part II.

Mech-Eye Industrial 3D Cameras

Scan the QR code to access datasheets



- Detailed and accurate 3D point clouds
- Ambient light resistance
- Short capture time
- IP65 water and dust resistance
- Rugged aluminum alloy housing
- MTBF (Mean Time Between Failures): $\geq 100,000$ hours

Specification	DEEP-GL	NANO ULTRA-GL	NANO-GL	UHP-140-GL
Working distance ^[1]	1200-3500 mm	250-800 mm	300-600 mm	300 ± 20 mm
Near FOV	1200 × 1000 mm @ 1.2 m	220 × 165 mm @ 0.25 m	220 × 150 mm @ 0.3 m	135 × 90 mm @ 0.28 m
Far FOV	3500 × 2800 mm @ 3.5 m	770 × 550 mm @ 0.8 m	440 × 300 mm @ 0.6 m	150 × 100 mm @ 0.32 m
Resolution	Depth map: 2048 × 1536	2400 × 1800	1280 × 1024	2048 × 1536
	RGB: 2000 × 1500			
Megapixels	/	4.3 MP	1.3 MP	3.0 MP
Point repeatability Z (σ) ^[2]	1.0 mm @ 3.0 m	0.1 mm @ 0.6 m	0.1 mm @ 0.5 m	2.6 μ m @ 0.3 m
VDI/VDE accuracy ^[3]	3.0 mm @ 3.0 m	0.1 mm @ 0.6 m	0.1 mm @ 0.5 m	0.03 mm @ 0.3 m
Typical capture time	0.5-0.9 s	0.5-0.9 s	0.6-1.1 s	0.6-0.9 s
Baseline	300 mm	86 mm	68 mm	80 mm
Dimensions	366 × 77 × 92 mm	125 × 46 × 76 mm	145 × 51 × 85 mm	260 × 65 × 142 mm
Weight	2.4 kg	0.7 kg	0.7 kg	1.9 kg
Light source	Red Laser (638 nm, Class 2)	Blue LED (440 nm, RG2)	Blue LED (459 nm, RG2)/White LED(RG2)	Blue LED (459 nm, RG2)
Image sensor	Sony CMOS for high-end machine vision	High-performance CMOS for high-end machine vision	Sony CMOS for high-end machine vision	
Operating temperature	-10-45°C	0-45°C		
Communication interface	Gigabit Ethernet			
Input	24V DC, 3.75 A		24V DC, 1.5 A	24V DC, 3.75 A
Safety and EMC	CE/FCC/VCCI/KC/ISED/NRTL			
IP rating	IP65			
Cooling	Passive			

Mech-Eye DEEP-GL

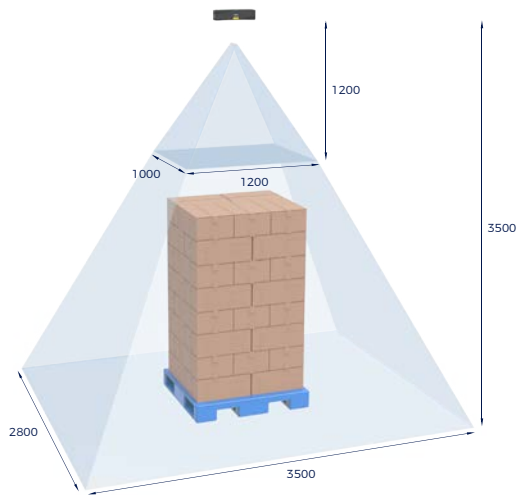

Mech-Eye NANO ULTRA-GL

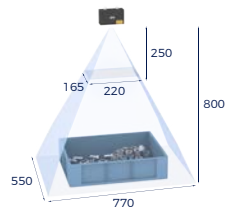

Mech-Eye NANO-GL

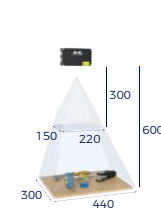

Mech-Eye UHP-140-GL



Field of view (mm)

[1] Multiple focal distances are available in a camera model. For further details, please scan the QR code to access camera datasheets.

[2] One standard deviation of 100 Z-value measurements of the same point. The measurement target was a ceramic plate.

[3] According to VDI/VDE 2634 Part II.

Industrial 3D Camera Mech-Eye LSR L-GL

Long-Range Working Distance



MTBF (Mean Time Between Failures): $\geq 100,000$ hours

High Accuracy | Large FOV | Ambient Light Resistance

The next-gen Mech-Eye LSR L-GL can generate accurate, complete, and detailed 3D point cloud data of a wide variety of objects under severe ambient light interference ($> 30,000$ lx).



Track links

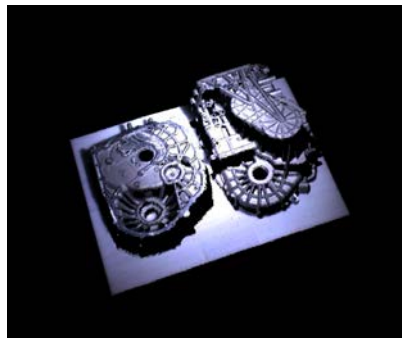

Gearbox housings

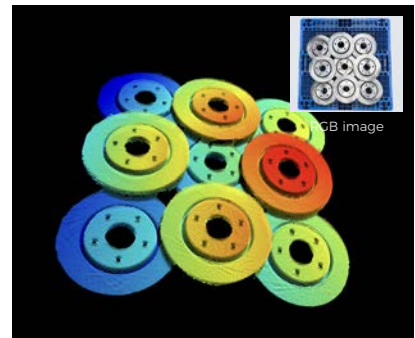

Brake discs
Color rendered by height

Point clouds captured by Mech-Eye LSR L-GL under challenging light conditions of $> 30,000$ lx @ 2.0 m

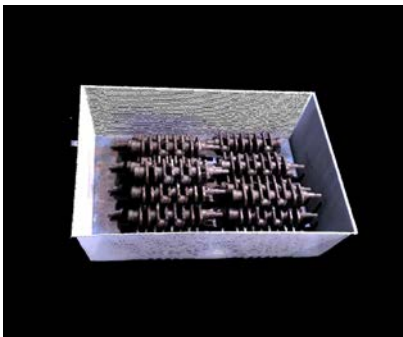

Crankshafts

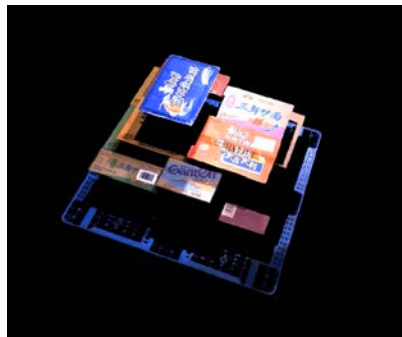

Colored cartons



Colored sacks

Point clouds captured by Mech-Eye LSR L-GL under challenging light conditions of $> 30,000$ lx @ 2.0 m

Industrial 3D Camera Mech-Eye PRO

Medium-Range Working Distance



MTBF (Mean Time Between Failures) \geq 100,000 hours

High Accuracy | Fast Scanning Speed | Blue and White Light Options

Mech-Eye PRO delivers an extraordinary level of detail with super high accuracy. Capturing point clouds with accurate details takes as low as 0.3 s.



Dark and reflective objects
Mech-Eye PRO S-GL



Highly reflective metal parts
Mech-Eye PRO S-GL



Transparent groceries
Mech-Eye PRO S-GL

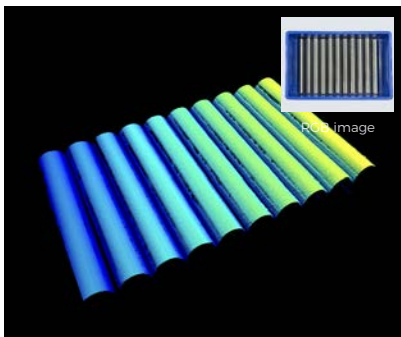

Reflective shafts
Mech-Eye PRO S-GL
Color rendered by height



Colored goods
Mech-Eye PRO M-GL



Colored cartons
Mech-Eye PRO M-GL

Point clouds captured under typical indoor lighting conditions

Industrial 3D Camera Mech-Eye NANO-GL

Short-Range Working Distance



MTBF (Mean Time Between Failures): $\geq 40,000$ hours

Ultra-Small Size | High Accuracy | Ambient Light Resistance

Mech-Eye NANO-GL (accuracy: 0.1 mm @ 0.5 m) can create 3D data of most complex parts with extraordinarily high accuracy.

In space-critical applications, Mech-Eye NANO-GL is easy to install and shows outstanding flexibility thanks to its ultra-small size (145 × 85 × 51 mm).

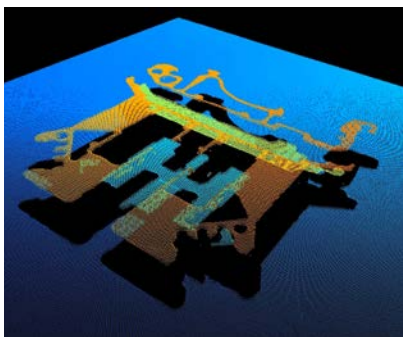

Precision component

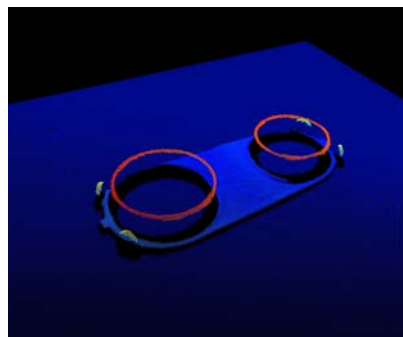

Thin objects
(only 0.6 mm thick)



Collection of small objects

Point cloud examples captured by Mech-Eye NANO-GL

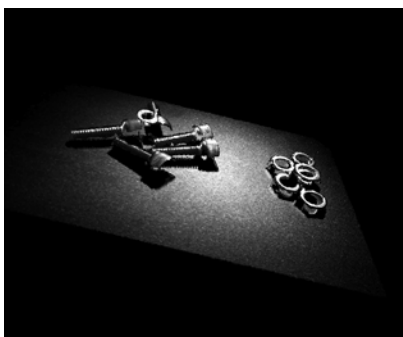

Screws and nuts



Car charging port



Small parts

Point cloud examples captured by Mech-Eye NANO-GL

Industrial 3D Camera

Mech-Eye NANO ULTRA-GL

Short-Range Working Distance



MTBF (Mean Time Between Failures) \geq 100,000 hours

Ultra-High Precision | Palm Size | Ideal for Welding, Precision Part Picking and Fine Assembly

Mech-Eye NANO ULTRA-GL, featuring impressive ambient light resistance and anti-reflection capability, can capture clear, detailed point clouds of reflective weldments and metal parts even under strong light ($> 60,000$ lx)

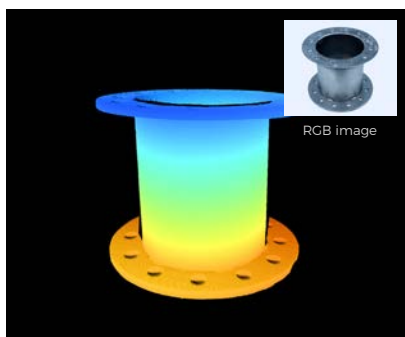

Cylindrical metal part

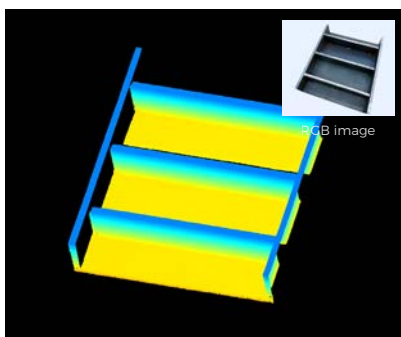

H-beam

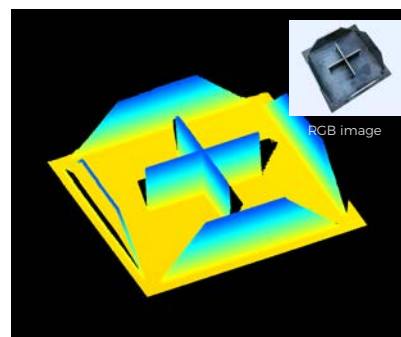

Sub-assembly component of the ship hull

Mech-Eye NANO ULTRA-GL @ 0.6 m, color rendered by height

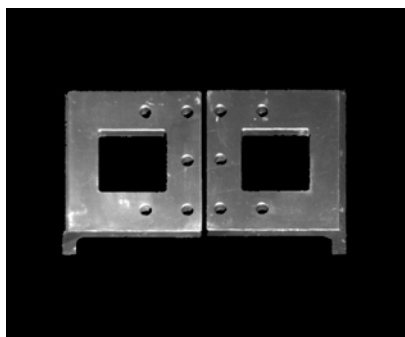

Shiny steel plates with holes

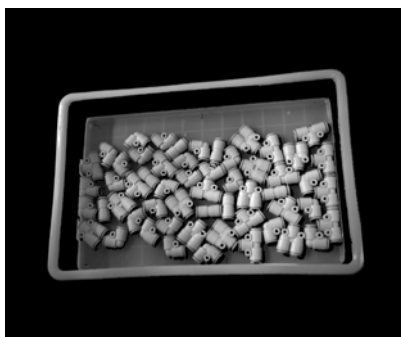

Gas connectors

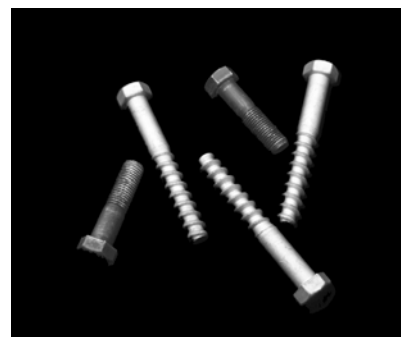

Bolts

Mech-Eye NANO ULTRA-GL @ 0.6 m

Industrial 3D Camera

Mech-Eye UHP-140-GL

Short-Range Working Distance



MTBF (Mean Time Between Failures) \geq 100,000 hours

Micron-Level Accuracy | Robust Anti-Reflection Performance | Advanced Image Stitching Algorithms

Mech-Eye UHP-140-GL is designed to inspect or measure the subtlest features and defects (accuracy: 0.03 mm @ 0.3 m; standard: VDI/VDE 2634 part II of Germany).

Coupled with advanced image fusion and anti-reflection 3D reconstruction algorithms, Mech-Eye UHP-140-GL can effectively reduce blind spots and generate high-quality point clouds of reflective and complex-shaped parts.

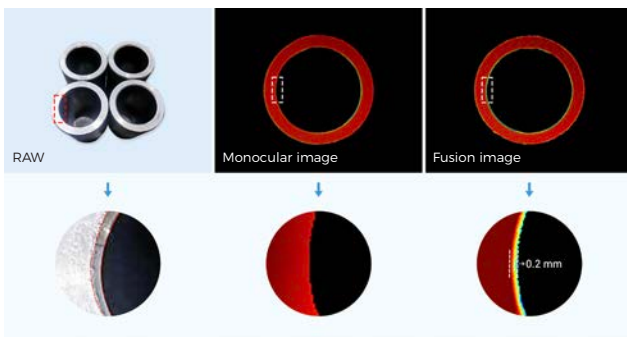

Round positioning hole with chamfered edges

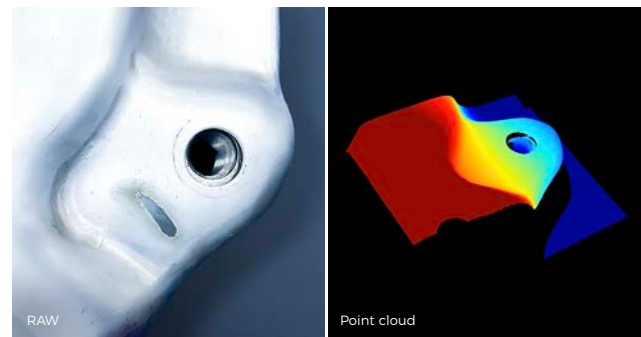

Threaded hole

Mech-Eye UHP-140-GL @ 0.3 m, color rendered by height

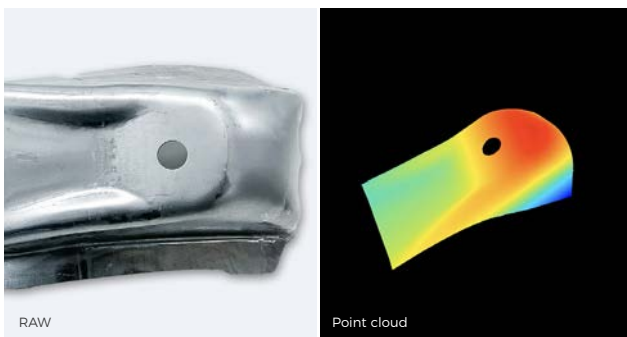

Reflective curved sheet metal part

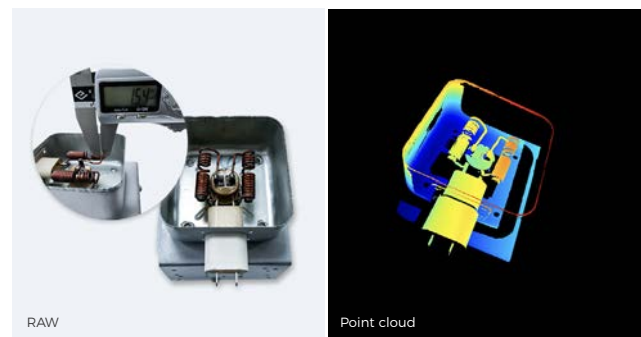

Reflective enameled copper wire with a diameter of about 1.5 mm

Mech-Eye UHP-140-GL @ 0.3 m, color rendered by height

Mech-Vision

Machine Vision Software

Mech-Vision is an industry-leading machine vision software. It is designed to quickly build vision applications, whether simple or complex. With Mech-Vision, users can manage a wide range of vision tasks, including identification, localization, inspection & measurement, etc.

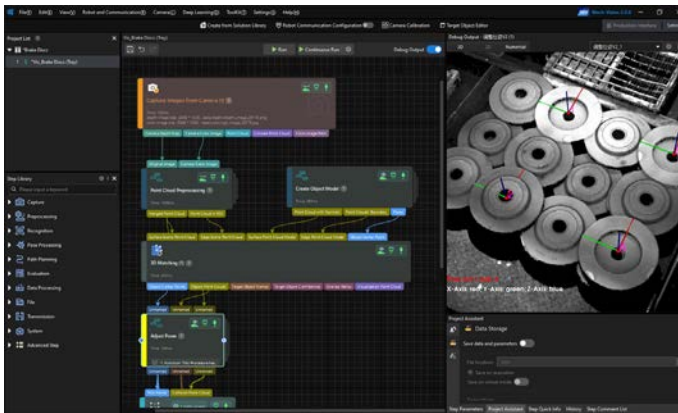

Build your vision applications efficiently

- Intuitive solution-oriented graphical user interface
- Drag-and-drop programming simplifies setup without writing a line of code
- Visualized configuration

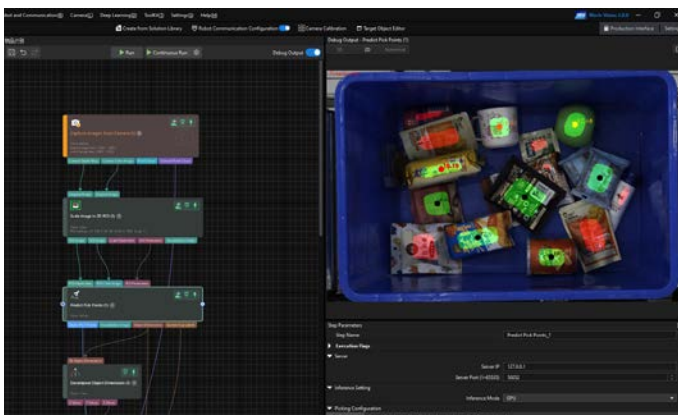

Manage complex vision applications with extensive tools

- Powerful algorithms: 2D/3D matching, 2D/3D deep learning, 2D/2.5D measurement, etc.
- Integrated machine vision tools: matching model, pick point editor, automatic calibration, caliper, etc.
- The **3D Workpiece Recognition** tool delivers recognition results in 1 sec, enabling easier and faster deployment of various loading and handling applications

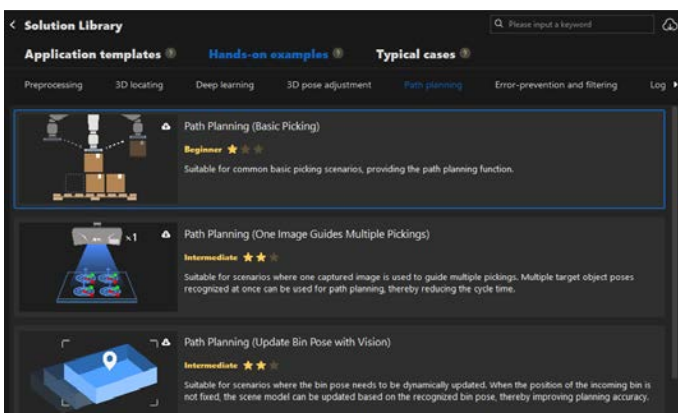

Develop vision applications easily and flexibly

- **Robust Solution Library:** get faster application deployment by adapting an existing project after simple modifications
- **Production Interface** for easy production status monitoring and data reporting
- Multiple languages: English, Japanese, Chinese, and Korean

Mech-Viz

Robot Programming Software

Mech-Viz is a software product for efficiently implementing robotic applications without writing a line of code. Mech-Viz enables robots to manage demanding automation tasks with excellent stability, extraordinary flexibility, and outstanding consistency.

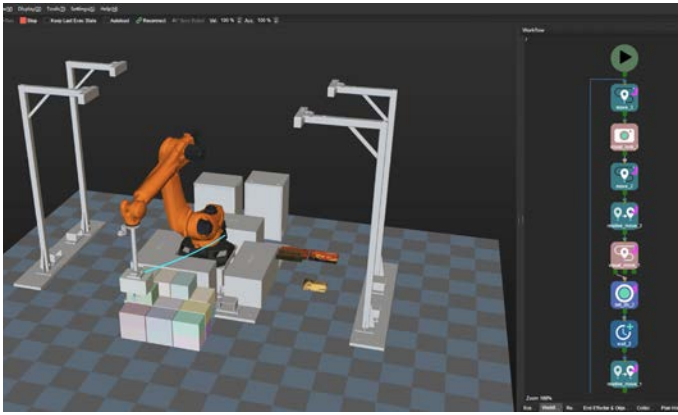
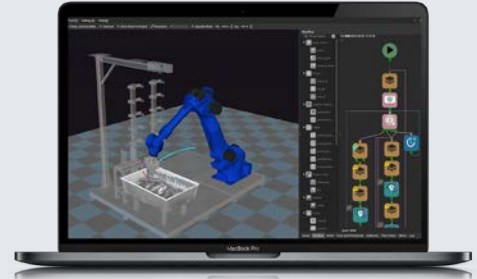

Intuitive Robot Programming

- Intuitive graphical user interface
- Code-free programming environment
- One-click simulation of robot path

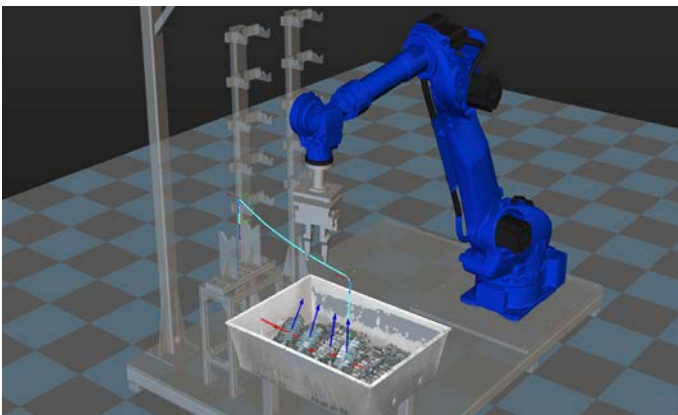

Powerful Algorithms for Reliable Robotic Operation

- Motion planning and collision detection
- Multi-pick depalletizing algorithms
- Picking strategies: multiple pick points, rotational symmetry, etc.

ABB	KUKA	YASKAWA	FANUC	Kawasaki
NACHI	DENSO	UNIVERSAL ROBOTS	STÄUBLI	EFORT
MITSUBISHI ELECTRIC	ROKAE	ELITE ROBOTS	PEITIAN ROBOTICS	TM ROBOT
ESTUN ROBOTICS	INOVANCE	AUBO	DOBOT	FAIRIND
HAAS ROBOT	HD HYUNDAI ROBOTICS	JAKA	SIASUN	DELTA

Flexible and Easy Implementation

- Support for almost all major-brand robots
- Streamlines configuration and redeployment with robot path reporting and tracking capabilities
- Multiple languages: English, Japanese, Chinese, and Korean

Mech-DLK

Deep Learning Software

Mech-DLK is a versatile deep learning software solving complex machine vision tasks. It enables users to rapidly train models and easily solve demanding vision applications, including overlapping object recognition and classification, complex defect detection, character reading, etc.

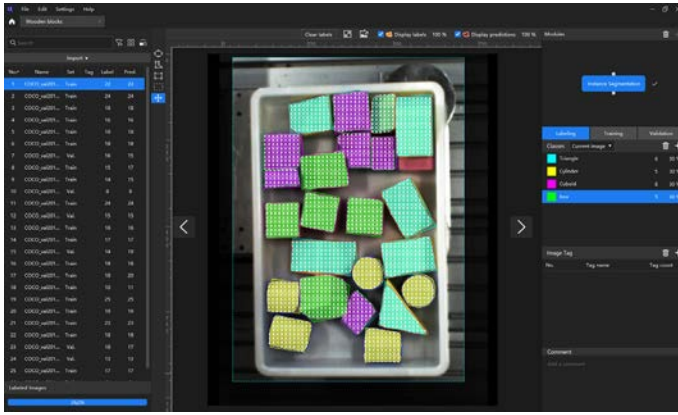

Train models efficiently without writing a line of code

- Intuitive code-free user interface
- Visualized model validation
- Advanced data augmentation: train models with smaller image sets
- **Finetune** function: leverage pre-trained models to expedite training, rather than train a model from scratch

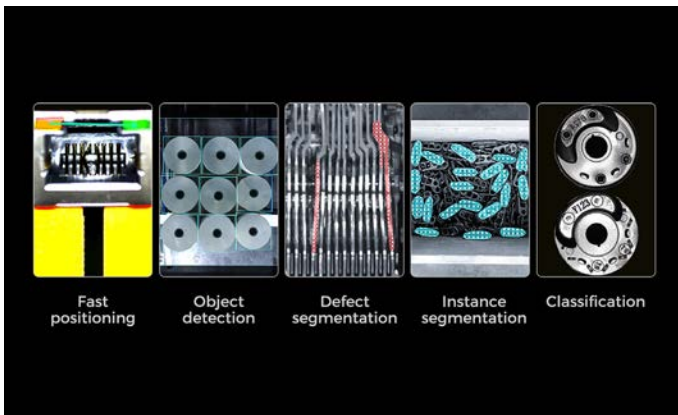

Manage complex machine vision tasks with speed and accuracy

- Manage complex vision applications with powerful algorithms such as fast positioning, defect segmentation, and instance segmentation
- **VFM labeling tool, smart labeling tool** and **pre-trained labeling tool** simplify the labeling process, saving time and effort



Integrate your vision tasks into your production environment easily

- Multi-language SDKs: C, C++, C#, and Python
- Easy integration with Mech-Vision for quick deployment

Example Cases

Scan QR code
to watch videos



**Vision-Guided
Case Depalletizing**



**Vision-Guided
Case and Tote Depalletizing**



**Vision-Guided
Sack Depalletizing**



**Vision-Guided
Machine Tending of Drive Gears**



**Vision-Guided
EV Charging**



**Vision-Guided
Bin Picking of CV Joints**



**Subframe Inline
Measurement**



**Vision-Guided
Car Door Inner Panel Picking**

Example Cases

Scan QR code
to watch videos



**Vision-Guided
Machine Tending of Countershafts**



**Vision-Guided
De-racking of Stamping Parts**



**Vision-Guided
Heavy-Duty Truck Tire Assembly**



**Vision-Guided
Machine Tending of Battery Modules**



**Vision-Guided
Tote Depalletizing**



**Vision-Guided
Depalletizing of Shrink-Wrapped
Bottles**



**Vision-Guided
Bolt Tightening**



**Inline Measurement of
Bumper Beams**

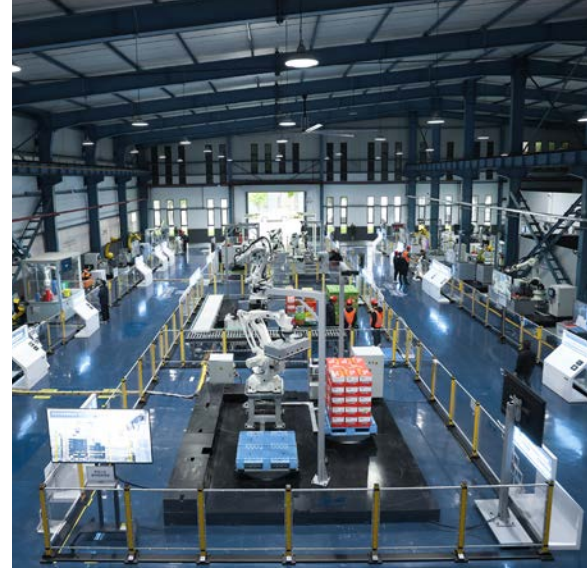
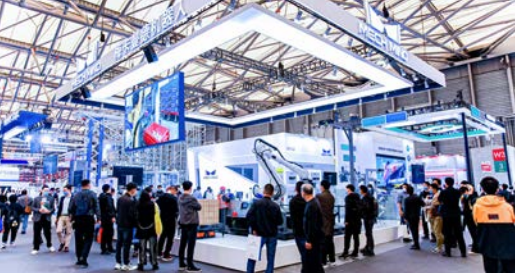

About Mech-Mind

Mech-Mind is an industry-leading company focusing on industrial 3D sensors and software suites for intelligent robotics. By combining 3D vision with AI technology, Mech-Mind brings automation to the next level and empowers partners and system integrators to manage the most challenging automation tasks, including bin picking, depalletizing & palletizing, picking & placing, and more.

One of the Highest-Funded AI + Robotics Companies

Founded in 2016, Mech-Mind has closed its Series C+ with total funding of > USD 200 million. Backed by Intel and other global top investors, Mech-Mind has been one of the highest-funded AI + robotics companies all over the world.

Create Success Together with Partners and Integrators

Excellent usability, approved quality, high flexibility, comprehensive service, and competitive price, that's what we stand for and how we help our customers and partners to exceed in their business. Our mature solutions empower system integrators and partners to solve the most demanding applications and bring automation to the next level.

World-Class Team with Deep Technical Knowledge

Mech-Mind assembles highly qualified experts with rich technical knowledge in 3D sensing, vision and robotics algorithms, robotics software, and intelligent robotic solutions.

10,000+ Cameras Deployed

Mech-Mind partnered with industry-leading companies and has deployed applications in 50+ regions. By delivering cutting-edge technology and reliable solutions, Mech-Mind has created visible ROI for global customers across diverse industries, including automotive, metal and machining, logistics, home appliances, food and beverage, etc.

10,000+ cameras
installed worldwide

> \$200 million
total funding

50+
regions

Customers and Partners



Compatible with Major Robot Brands



3D VISION & AI FOR ROBOTS AND MORE



Get the most from Mech-Mind's 3D vision -
get in touch with us!

Website: www.mech-mind.com

E-mail (business): info@mech-mind.net

E-mail (PR & marketing): marketing@mech-mind.net

Learning guidance to deploy your vision
application **STEP BY STEP**, please visit

Documentation: docs.mech-mind.net

Online community: community.mech-mind.com
